

# SPECIFICATIONS

## **- HYDRAULIC 50/50 SYSTEM**

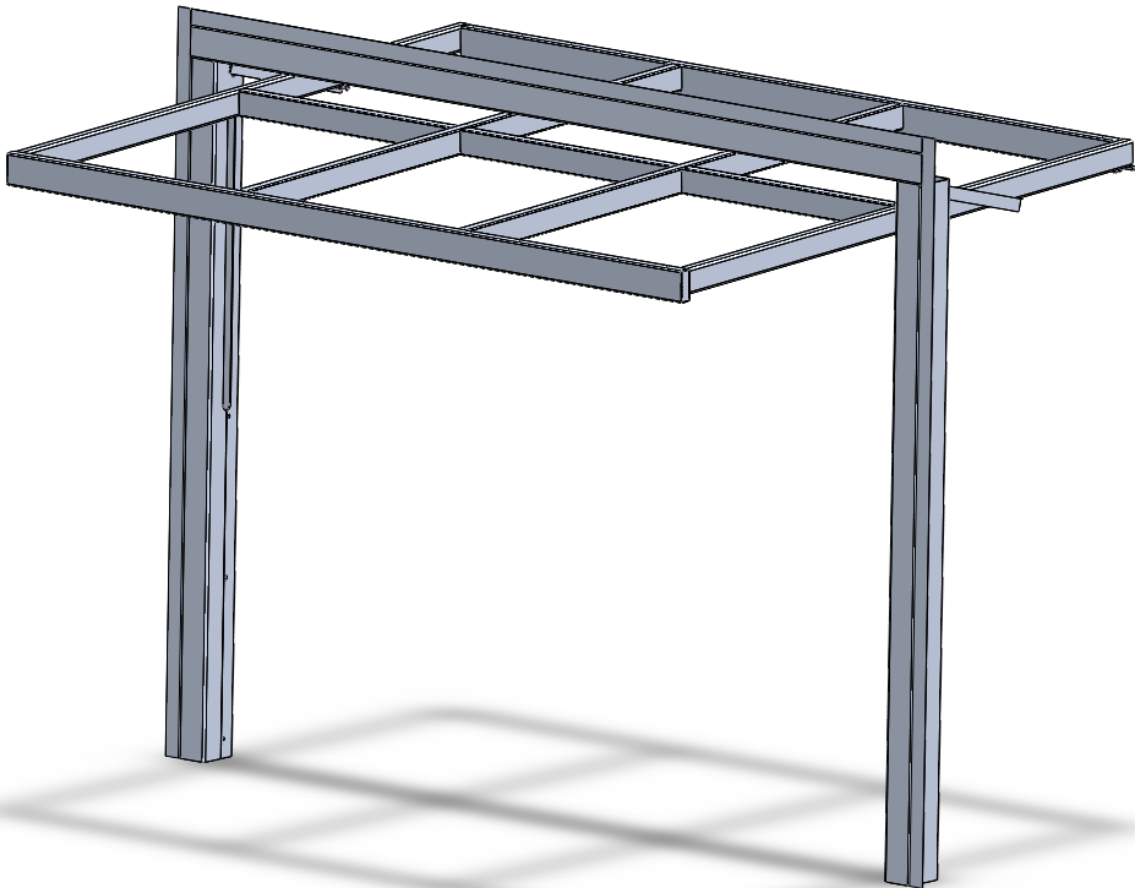

**PART 1 - GENERAL**

## 1.01 DESCRIPTION

## A. General

1. Furnish Hydraulic 50/50 System complete from one manufacturer. Provide all labor, materials, tools, and equipment to furnish the Hydraulic 50/50 System complete as herein specified.

## 1.02 RELATED WORK BY OTHERS

- A. Preparation of opening including jambs and header will be by General Contractor. Any deviation of site conditions contrary to approved shop drawings must be called to the attention of the architect.
- B. All header, blocking, support structures and jambs as required.
- C. Paint or otherwise finishing all trim and other materials adjoining door.
- D. Provide hydraulic fluid in quantity necessary for proper system operation.

## 1.03 SUBMITTALS

## A. Product Data

1. Submit manufacturer's product data and roughing-in diagrams.
2. Complete shop drawings are to be provided prior to fabrication indicating construction and installation details.

## 1.04 QUALITY ASSURANCE

- A. Provide each Hydraulic 50/50 System as a complete unit by one manufacturer, including frames, panels, brackets, guides, hardware, operators, and installation accessories to suit opening.
- B. Wind Loading: Design and reinforce Hydraulic 50/50 system to withstand a wind loading pressure to comply with state and federal code requirements.
- C. Preparation of the opening shall conform to current criteria set forth by the International and Standard Building Code.

## 1.05 PRODUCT DELIVERY, STORAGE AND HANDLING

- A. Proper storage of the system before installation and continued protection during and after installation will be the responsibility of the general contractor.

## 1.06 WARRANTY

- A. All materials and components, supplied by Crown, shall be guaranteed against defects in material and workmanship, for a period of one year from date of delivery.
- B. Materials and components supplied by other than Crown is not included in this warranty.
- C. Reference std. Crown warranties for further information.

**PART 2 - PRODUCTS****2.01 ACCEPTABLE MANUFACTURERS**

- A. Subject to compliance with requirements, manufacturers offering products which may be incorporated into the work, include, but are not limited to, the following:

**Crown Doors, LLC**  
**135 McLeod Avenue South**  
**Plato, MN. 55370**  
**(320) 238-2616**  
[www.crowndoors.com](http://www.crowndoors.com)  
[info@crowndoors.com](mailto:info@crowndoors.com)

- B. Upon compliance with all the criteria specified in this section, manufacturers wishing to bid products similar to the product specified must submit to the architect - 10 days prior to bidding - complete data in support of compliance. The submitting manufacturer guarantees the proposed substituted product complies with the product specified and as detailed on the drawings.

**2.02 MATERIALS**

- A. Product to be Hydraulic 50/50 System as furnished by Crown Doors, LLC
1. Construct operable panel and frame sections with structural steel (of ASTM-A500 grade minimum) framing to comply with applied wind code.
    - Optional: 304 stainless steel framing for highly corrosive environments.
  2. Operable panel and frame shall be constructed of structural steel tubing, and other structural steel shapes, and shall be designed to the same loading requirements for live, dead and wind loads as the surrounding construction.
  3. System shall be designed so that no center "cane bolt" is required in the floor.
  4. Operable panel and frame shall be factory-welded at all joints and connections, with smooth welds not to exceed 1/4" [6] thickness.
  5. Inside-Sash (infill) glass retainer system shall be factory pre-installed and seam-sealed, and necessary setting blocks, spacers, butyl and foam tape shall be supplied.
  6. System frame, operable panel, and factory pre-installed, inside-sash glass retainer shall be primed with gray-zinc, powder-based, epoxy primer, and finished with manufacturer's standard powder-coat.
  7. Factory-Supplied neoprene seals/weather stripping will be shipped loose for field-install to protect against damage during transport.
- B. 50/50 System shall be operated by hydraulic cylinders that are mechanically fastened to the panel frames.
1. Cylinders will be designed to carry the required loads during operation, open position, and closed position. Internal stops will be installed so as not to allow over-extension of the cylinders, therefore

- restricting the system from opening or closing beyond its limit.
2. Lift straps or cables, horizontal top and bottom drive shafts, pulleys and strap or cable “kick outs” are unacceptable.
  3. System shall be locked closed by means of the integral lock tabs, within frame system.
- C. Power Operator - Standard voltage is 220-240v, single phase.
1. Constant contact push-button or key-switch controls for separate mounting.
  2. Power unit to power (2) hydraulic cylinders which open and close the system. Power unit to be pre-wired and factory tested.
  3. “Open-Close” control units will be wired for constant-hold operation.
  4. Incoming electrical source to hydraulic power unit to be supplied by others (manufacturer’s standard).
  5. Each door operator shall have thermal overload protection for the motor.
- D. Finishes
1. Entire system frame, operable panel, and factory pre-installed, inside-sash glass retainer shall be primed with gray-zinc, powder-based, epoxy primer, and finished with manufacturer’s standard powder-coat.
    - Optional Finishes
      - i. RAL powder-coat colors in gloss or satin
      - ii. Custom matched powder-coat color
- E. Available Accessories/Options
1. Photoelectric or lead-edge pressure sensor that stops (or stops and reverses) the downward movement of the door/window.
  2. Warning horn/Strobe light assembly
  3. Remote receiver w/transmitter
  4. 3-Phase option
  5. External, weather-resistant, “open-close” control wired for constant-hold
  6. Front-Set (Curtainwall) glass retainer system

## 2.03 OPERATION

- A. The Hydraulic 50/50 System shall be raised/lowered in the opening using a constant-contact push-button or key switch, operating hydraulic cylinders mounted to the operable panel axel.

## **PART 3 - EXECUTION**

**3.01 SAFETY**

- A. Hydraulic power unit to have a manual emergency let-down valve for closing the system in case of a power outage.
- B. Hydraulic 50/50 System to incorporate pressure compensated orifice valves
- C. Photoelectric or lead-edge pressure sensor optional.

**3.02 INSTALLATION**

- A. Installation of the Hydraulic 50/50 System shall be by a contractor familiar with this type of installation and be in strict accordance with the approved build drawings and manufacturers standard printed specifications, instructions, and recommendations. All moving parts will be left in good operating condition.
- B. Permanent or temporary electric wiring shall be brought to the power unit location before installation. After the Hydraulic 50/50 System is installed, the general contractor assumes the responsibility of any damage to the system or system components during construction until the building is turned over to the owner.
- C. Fill reservoir with hydraulic fluid (provided by others). Use ATF for cold weather applications or #32 hydraulic fluid for all other applications.

**3.03 CLEANING**

- A. All surfaces shall be wiped clean and free of handprints, grease, and oil.

**3.04 TRAINING**

- A. Installer shall demonstrate proper operation and maintenance procedures to owner's representative.
- B. Operating keys and owner's manual shall be provided to owner's representative.